

Application

MCL-E is a yarn break **capacitive sensor** devoted to high count yarns, especially **carpet yarns**.

MAIN FUNCTION: To control the linear motion of any kind of textile yarns.

When the yarn breaks or when scrolling stops, the **MCL-E** will inform the user (flashing LED) that a position is defective. It can also activate a **yarn cutter** or stop the position giving a **LOW or HIGH signal** to an automate.

Any kind of material able to keep electrostatic charge can be checked by the **MCL-E**.

PRINCIPLE: The **MCL-E** probe will check the tension variations produced by the electrical charges into the yarn in motion. Typically a 8000 dtex yarn running at 100 m/mn can easily be checked. The **MCL-E** is insensitive to dust and vibrations.

ELECTRICAL PROTECTION: The **MCL-E** is protected against reversed polarity and high level overload on output. It shows a very high level of EMC, electromagnetic compatibility : >4 kV.



Characteristics:

- Power supply : 18 to 30 V DC
- NPN or PNP output
- Inhibition switch
- External inhibition input
- Visual flashing alarm (red LED)
- Connection through cable, or Lumberg 2,5 MSFW 5 or any kind of connector on demand
- The MCL-E sensitivity is adapted to operator's requirement

These characteristics are adapted to operator's requirements. (Referenced to the codification board)

Dimensions (mm)

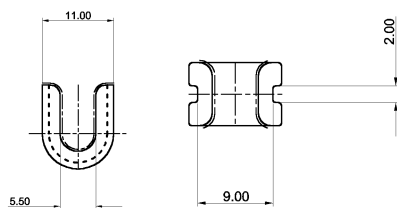
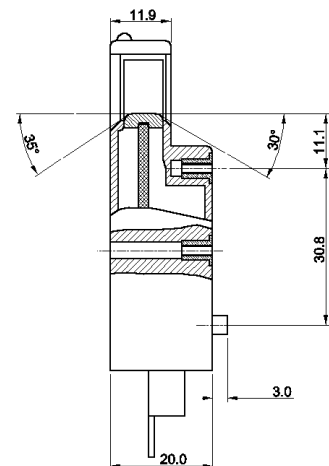
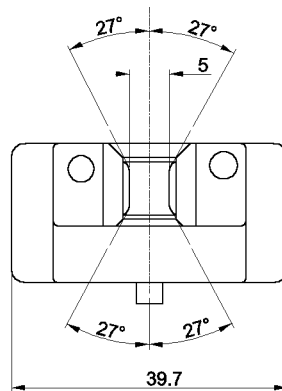
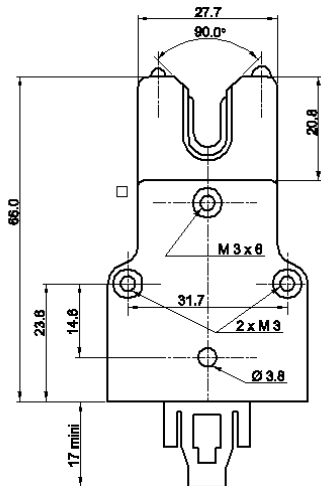

One of these guides can be adapted on the MCL-E :

Ref. : 424001 Ref. : 424002

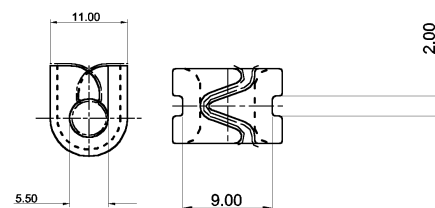

Characteristic codification

MCL-E-			X	X	X	X	X	X
Inhibition / Pilot light / Inhibition								
Push button	LED	External input						
Without	Without	Without	1					
With	Without	Without	2					
Without	With	Without	3					
With	With	Without	4					
Without	Without	With	5					
With	Without	With	6					
Without	With	With	7					
With	With	With	8					
Guides								
Ref. : 424001				1				
Ref. : 424002				2				
Connections								
By cable					1			
By connector					2			
Response time (ms)								
100						3		
200						4		
600						5		
900						6		
Output								
NPN Normally open (NO)							1	
PNP Normally open (NO)							2	
NPN Normally close (NC)							3	
PNP Normally close (NC)							4	
Fasten type								
Horizontally								H
Vertically								V

Example

MCL-E-81261H :

- 8 : with push-button, LED and external inhibition input
- 1 : with guide Ref. 424001
- 2 : with Lumberg 2,5 MSFW 5 connector
- 6 : response time of 900 ms
- 1 : NPN output Normally Open (NO)
- H : horizontally fasten

Sensors from the new range can be mounted on the FIL CONTROL standard rail (ref. : 423800), by the mean of bracket (ref. : 423802).

Technical characteristics

Parameters	Conditions	Min	Typ	Max	
Power supply voltage (V)		18	24	30	
Sensor consumption (mA)	Own current consumption at 24 V DC and at 25°C. External inhibition and output not connected	-	Indicator light ON	22	
			Indicator light OFF	7,5	
Ripple voltage at 100 Hz	Supply voltage peaks < 30 V	-	-	80%	
Delay between detection and move start (s)	On request	-	3	-	
Dropout voltage at the output (V)	NPN	-	0,5	1,1	
	PNP	-	1,7	2,3	
Min. current driven by the output (A)	NPN	1	-	-	
	PNP	0,5	0,8	-	
Max. voltage at the output (V)		-	-	50	
Logical level on the inhibition input (V)	Supply voltage = 24 V	10,7	High level	-	
			Low level	3,8	
Current in the inhibition input (mA)	Supply voltage = 24 V	-	-	Low level	5,3
Immunity to the perturbations (kV)	Positive and negative	4	-	Injected	-
				Inducted	-
				Radiated	-
Temperature range (°C)		-25	-	For storage	85
				For operation	50
Relative humidity		-	-	80%	

Setting up procedure

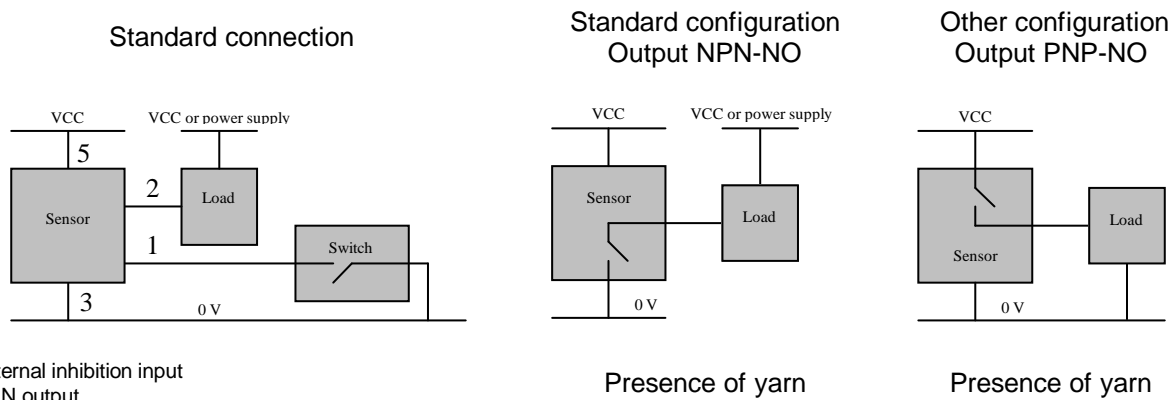

Global Operations

State	LED	Output	External input
Switch-on	Light-on	Inactive	Active level 0 (0V) Inactive level 1 (24V)
Inhibition	Light-on	Inactive	
Presence of yarn	Light-off	Inactive	
Absence of yarn	Blinking	Active	